

INSTRUCTION

STEERING DAMPER KIT

for Harley Davidson FLT 2014 up

Thank you for purchasing DAYTONA STEERING DAMPER KIT.

Product Features

- Stabilizes steering especially at high speed.
- Prevents the front forks from being twisted at high speed cornering.
- Bolt-on mount. The kit comes with complete bracket kit for easy mounting.



1. Read all instructions before use.
2. After installation, check to see if all the parts are correctly installed, and see if all the screws are torqued properly.
3. Do not adjust the damper while running.
4. Periodical inspection of the installed parts is required every 500km (300mile). If anything unusual may be found while driving, pull over at a safe place to check.

Install

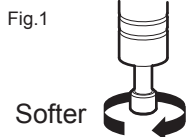

Before installing, turn the adjustable knob counter-clockwise to the end.

Softer

Remove a Outer Fairing Skirt & Turn Signal Brackets.

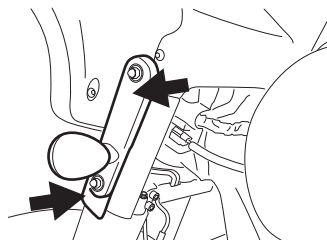
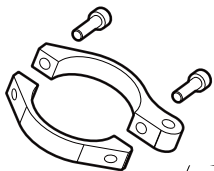

Fig.2

Place the FRONT FORK BRACKET(#5) on the right side over the triple tree.

The distance between the FRONT FORK BRACKET(#5) and triple tree becomes approx 65mm(2.6").

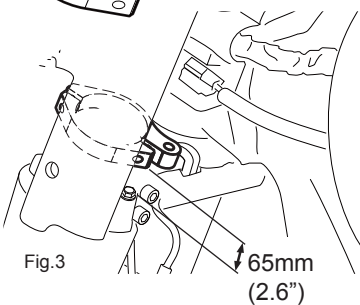
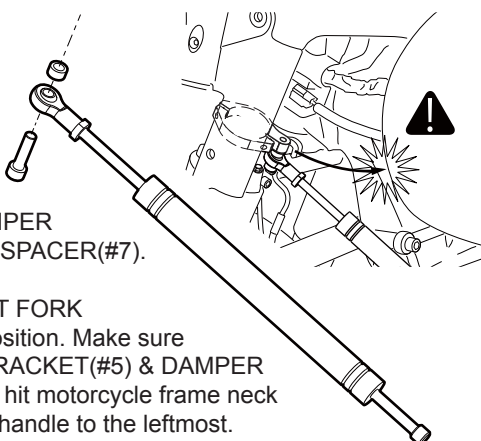
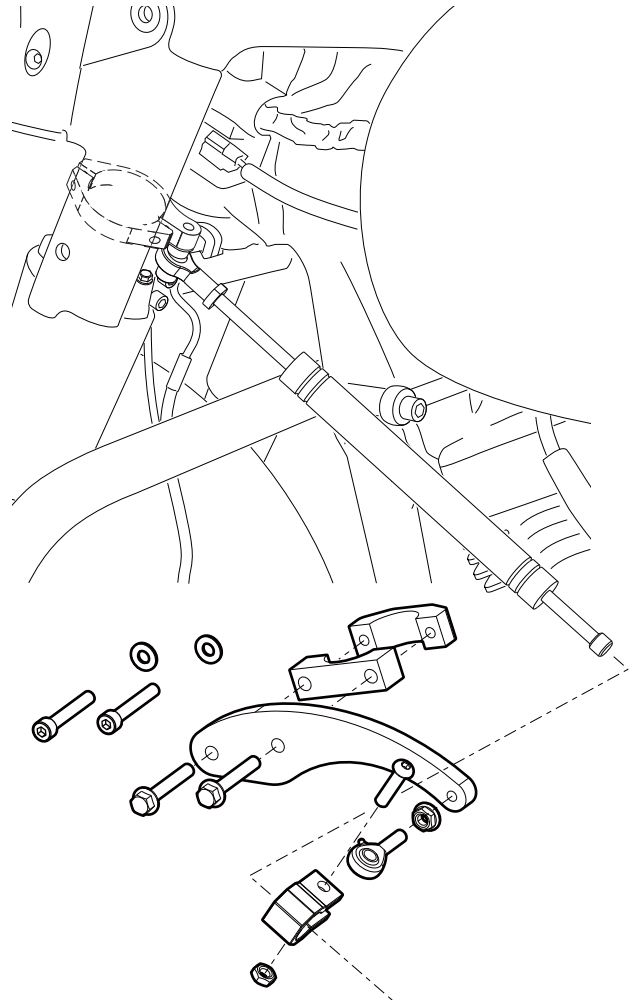

Fig.3



Connect the DAMPER BODY(#1) with a SPACER(#7).

Adjust the FRONT FORK BRACKET(#5) position. Make sure FRONT FORK BRACKET(#5) & DAMPER BODY(#1) do not hit motorcycle frame neck when turning the handle to the leftmost.



Install FRAME BRACKET(#2), FRAME CLAMP(#13) and BODY CLAMP(#10).

Adjust the DAMPER BODY(#1) position. Make sure DAMPER BODY(#1) doesn't hit any part of motorcycle when turning the handle to the leftmost and rightmost.

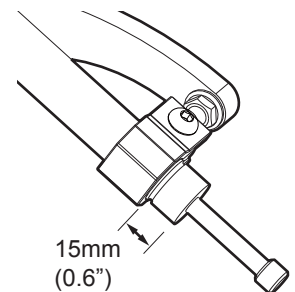

15mm (0.6")

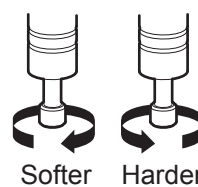

Softer

Harder

How to adjust the damping force

Turn the adjustable knob clockwise → Harder

Turn the adjustable knob counter-clockwise → Softer

