

# 01. CYLINDER HEAD / CYLINDER

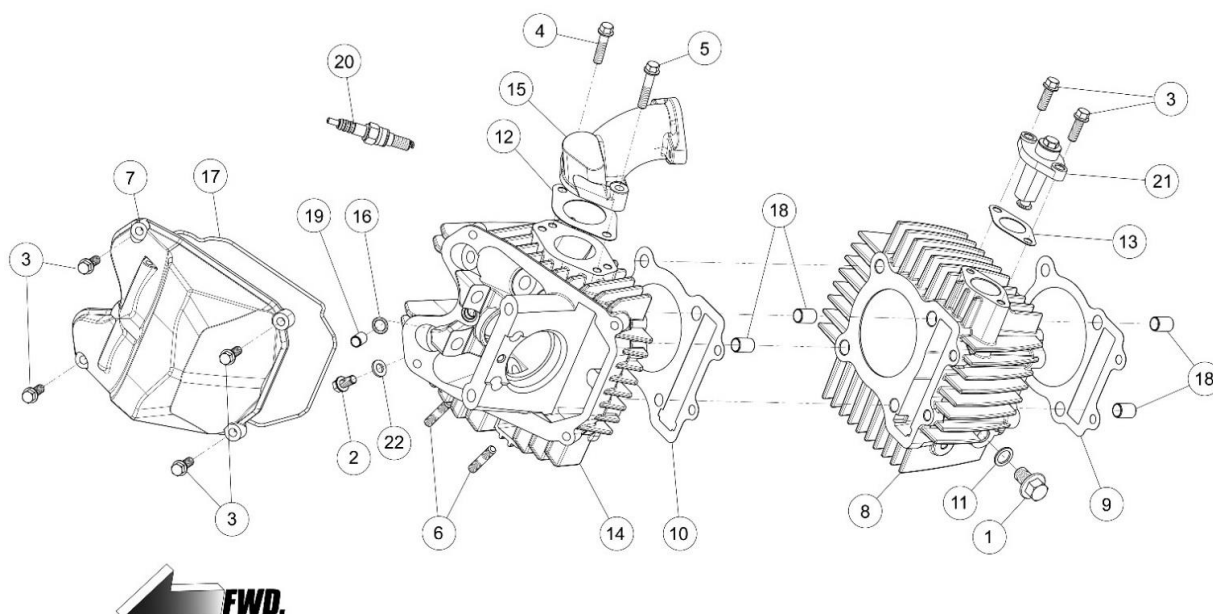

Ref No.	Part No.	DESCRIPTION	QTY	REMARK
1	86448	BOLT, HEXAGON FLANGE M10x16	1	
2	85877	BOLT, HEXAGON FLANGE M6x12	1	
3	86468	BOLT, HEXAGON FLANGE M6x18	6	
4	86466	BOLT, HEXAGON FLANGE M6x25	1	
5	86471	BOLT, HEXAGON FLANGE M6x30	1	
6	83703	BOLT, STUD M6x32	2	
7	88250	COVER, CYLINDER HEAD, BLACK	1	
8	89237	CYLINDER	1	BORE 62mm
9	86436	GASKET, BASE CYLINDER	1	
10	86440	GASKET, HEAD CYLINDER	1	
11	86476	GASKET, M10	1	
12	86405	GASKET, MANIFOLD	1	
13	86439	GASKET, TANSIONER CAM CHAIN	1	
14	86368	HEAD, CYLINDER	1	
15	86404	MANIFOLD, INTAKE	1	
16	86479	O-RING	1	
17	86434	O-RING, COVER HEAD	1	
18	83720	PIN, DOWEL $\Phi 10 \times \Phi 8.4 \times 14$	4	
19	83747	PIN, DOWEL $\Phi 8 \times \Phi 6.3 \times 12$	1	
20	86429	SPARK PLUG ER9EH-6N	1	STANDARD
20	87008	SPARK PLUG ER9EH	1	ALTERNATIVE
21	86396	TENSIONER, CAM CHAIN COMP	1	
22	86456	WASHER, $\Phi 6.3 \times \Phi 12 \times 1.5$	1	

## 02. VALVE MECHANISM

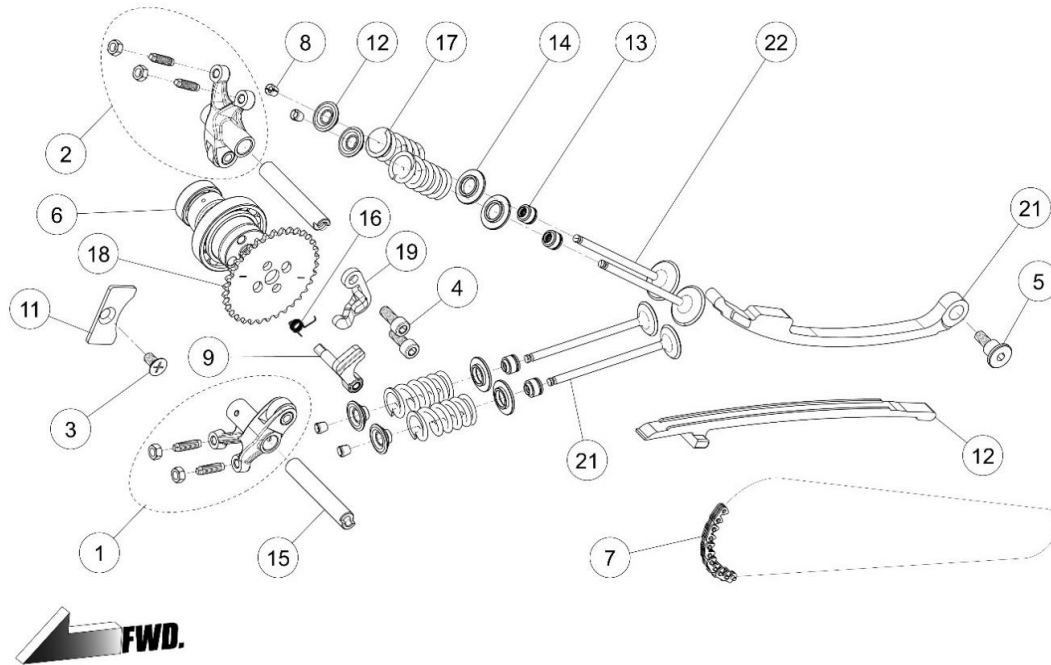

Ref No.	Part No.	DESCRIPTION	QTY	REMARK
1	86481	ARM, ROCKER ROLLER EXHAUST COMP	1	
2	86393	ARM, ROCKER ROLLER INTAKE COMP	1	
3	86460	BOLT, COUNTERSINK M6x15	1	
4	86883	SCREW M6X16	2	
5	86447	BOLT, TENSIONER	1	
6	87347	CAMSHAFT 00 ROLLER DECOMP ASM	1	
7	86391	CHAIN, CAMSHAFT DRIVE	1	94L
8	86402	COTTER, VALVE	8	
9	89681	SHAFT W/WEIGHT, DECOMP. VER3	1	
10	86395	GUIDE , CHAIN CAMSHAFT	1	
11	86389	PLATE, STOPPER CAM	1	
12	86400	RETAINER, SPRING VALVE	4	
13	86403	SEAL, VALVE STEM $\Phi$ 4.5	4	
14	86401	SEAT, SPRING VALVE	4	
15	86392	SHAFT, ROCKER	2	
16	87621	SPRING, RETURN DECOMP. VER2	1	
17	87343	SPRING, VALVE PLAN-G	4	
18	86879	SPROCKET, CAMSHAFT DRIVEN	1	34T
19	87620	PLATE, STOPPER DECOMP. VER2	1	
20	86394	TENSIONER, CAM CHAIN	1	
21	86623	VALVE, EXHAUST $\Phi$ 21	2	
22	86397	VALVE, INTAKE $\Phi$ 24.5	2	

### 03. PISTON / CRANKSHAFT

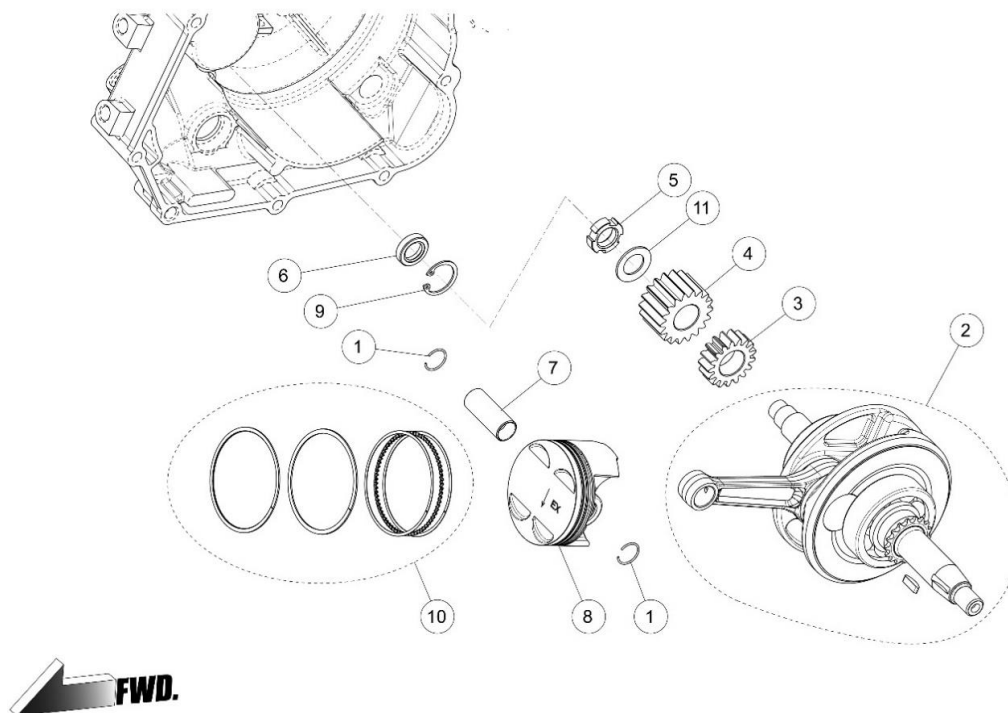

Ref No.	Part No.	DESCRIPTION	QTY	REMARK
1	86453	CLIP, PIN PISTON	2	
2	88421	CRANK SHAFT ASSY DT190FE	1	STROKE 62mm
3	86383	GEAR, OIL PUMP DRIVE	1	
4	86415	GEAR, PRIMARY DRIVE	1	
5	83768	NUT, SMALL M14	1	
6	86443	OIL SEAL, $\phi 12 \times \phi 20 \times 5t$	1	
7	86379	PIN, PISTON $\phi 14$	1	
8	86621	PISTON DT190	1	62mm
9	86462	RETAINING RING, RTWN22	1	
10	86380	RING SET, PISTON 62MM	1	
11	86411	WASHER, SPRING	1	

## 04. CRANKCASE

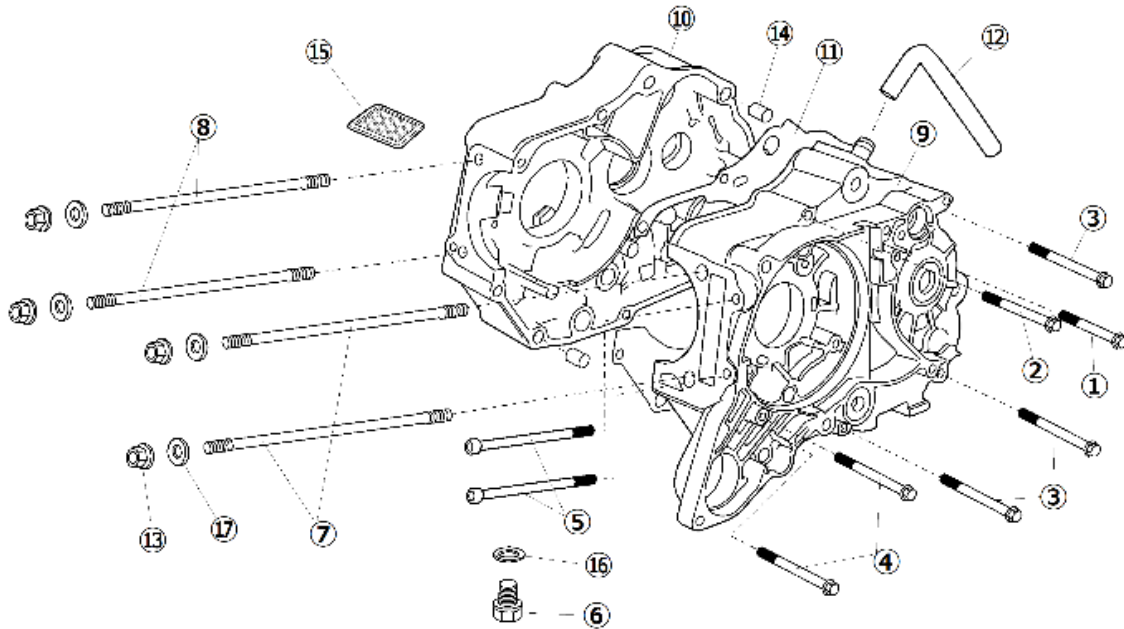

Ref No.	Part No.	DESCRIPTION	QTY	REMARK
1	86474	BOLT, HEXAGON FLANGE M6x55	1	
2	83761	BOLT, HEXAGON FLANGE M6x65	1	
3	86360	BOLT, HEXAGON FLANGE M6x70	3	
4	88864	BOLT, HEXAGON FLANGE M6x80	2	
5	86459	BOLT, HEXAGON SOCKET M6x108	2	
6	83755	BOLT, OIL DRAIN M12x15	1	
7	86444	BOLT, STUD A	2	
8	86445	BOLT, STUD B	2	
9	88847	CRANKCASE,LH ANIMA FE	1	
10	88848	CRANKCASE,RH ANIMA FE	1	
11	86438	GASKET, CRANKCASE	1	
12	86371	HOSE, BREATHER	1	
13	86451	NUT FLANGE, M8	4	
14	83720	PIN, DOWELΦ10xΦ8.4x14	2	
15	83751	OIL FILTER SCREEN	1	
16	83754	WASHER, OIL DRAIN M12	1	
17	86457	WASHER, GASKET M8	4	
18	88870	BOLT, M6X12	1	
19	88871	PLATE, START CLUTCH	1	

# 05. CLUTCH

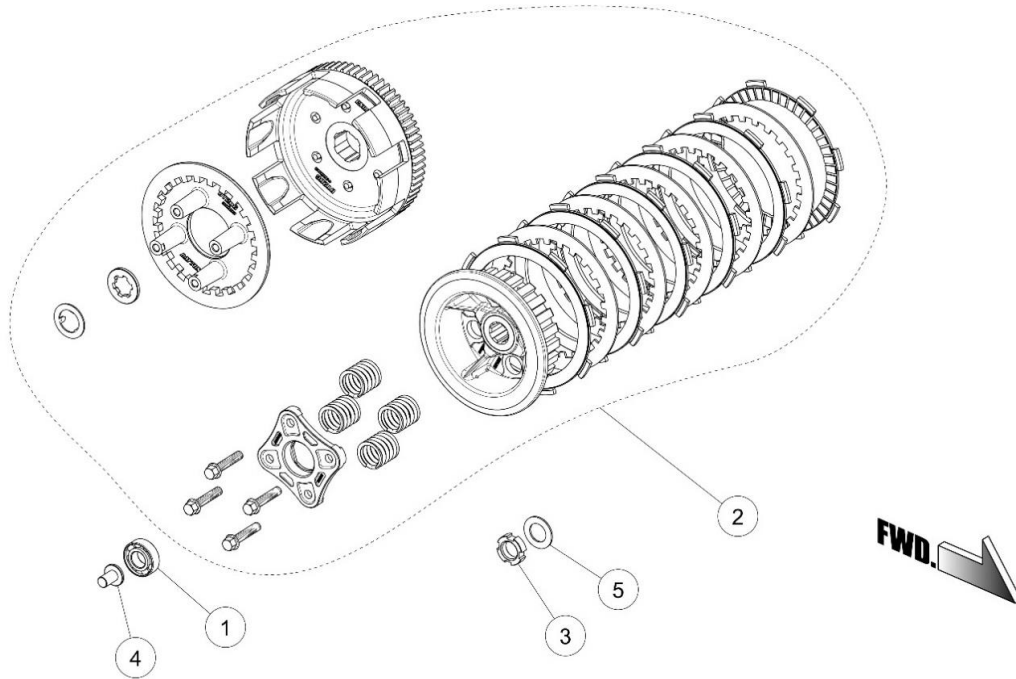

Ref No.	Part No.	DESCRIPTION	QTY	REMARK
1	83786	BEARING, #6000	1	
2	87619	CLUTCH COMP, W/FORGED GEAR	1	
3	83768	NUT, SMALL M14	1	
4	83787	PIN, LIFTER CLUTCH	1	
5	86410	WASHER, SPRING $\Phi 24 \times \Phi 14.2 \times 1.2$	1	

## 06. COVER CLUTCH

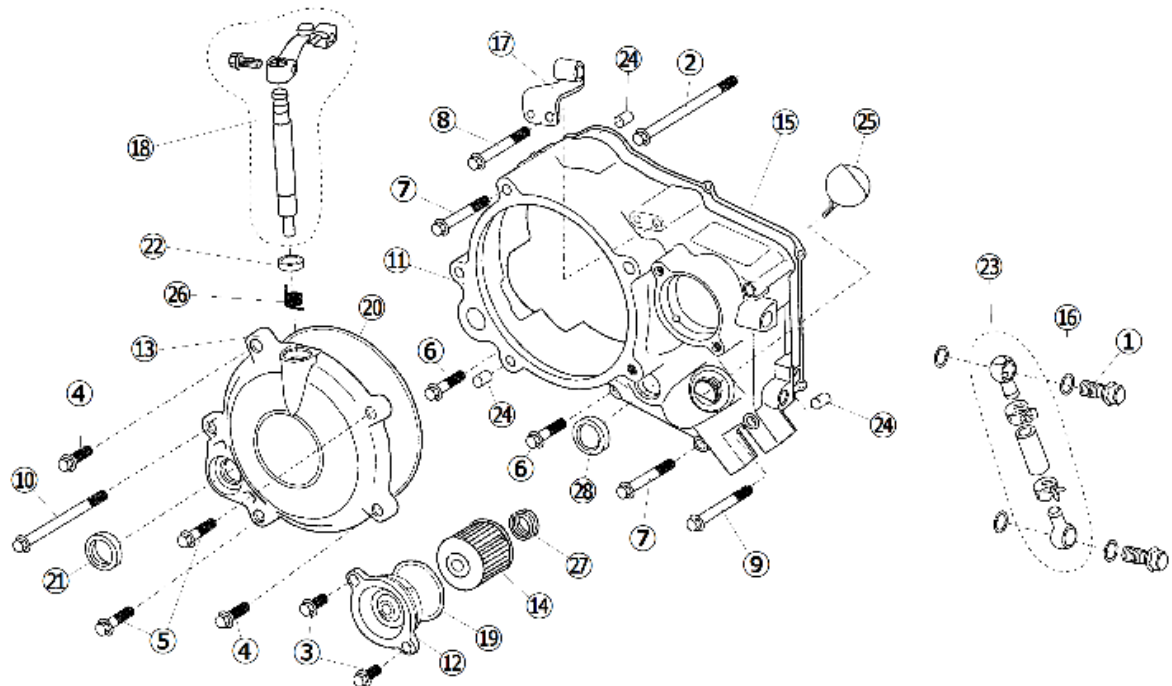

Ref No.	Part No.	DESCRIPTION	QTY	REMARK
1	86446	BOLT, BANJO M10x22.5	2	
2	88862	BOLT, HEXAGON FLANGE M6x115	1	
3	86486	BOLT, HEXAGON FLANGE M6x15	2	
4	86469	BOLT, HEXAGON FLANGE M6x22	2	
5	86485	BOLT, HEXAGON FLANGE M6x28	2	
6	86471	BOLT, HEXAGON FLANGE M6x30	2	
7	86473	BOLT, HEXAGON FLANGE M6x50	2	
8	86474	BOLT, HEXAGON FLANGE M6x55	1	
9	83759	BOLT, HEXAGON FLANGE M6x60	1	
10	86361	BOLT, HEXAGON FLANGE M6x90	1	
11	88863	COVER, CLUTCH	1	
12	86374	COVER, OIL FILTER	1	
13	86377	COVER, SMALL CLUTCH	1	
14	86384	FILTER, OIL	1	
15	86437	GASKET, COVER CLUTCH	1	
16	86476	GASKET, M10	4	
17	86412	HOLDER, CABLE CLUTCH	1	
18	86414	LEVER, CLUTCH COMP	1	
19	86432	O-RING, $\Phi 38.6 \times 2.6$	1	
20	86435	O-RING, COVER SMALL CLUTCH	1	
21	86441	OIL SEAL, $\Phi 16 \times \Phi 26 \times 7$	1	
22	86442	OIL SEAL, $\Phi 17 \times \Phi 10 \times 5$	1	
23	86406	OIL THROUGH COMP	2	
24	83747	PIN, DOWEL $\Phi 8 \times \Phi 6.3 \times 12$	4	
25	86386	RULER	1	
26	86413	SPRING, LEVER CLUTCH	1	
27	86375	SPRING, OIL FILTER	1	
28	86475	WINDOW, OIL LEVEL	1	

# 07. GEARBOX

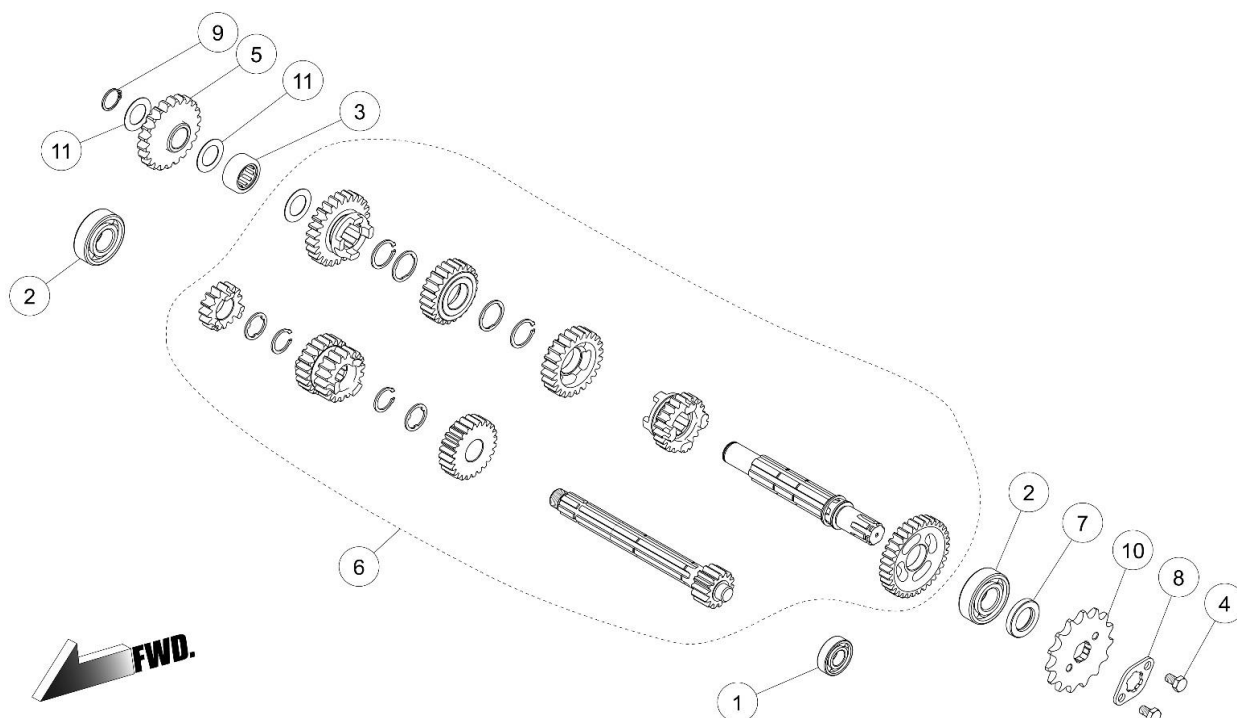

Ref No.	Part No.	DESCRIPTION	QTY	REMARK
1	83788	BEARING #6001	1	
2	83795	BEARING #6203	2	
3	80240	BEARING NK162712	1	
4	86464	BOLT, HEXAGON HEAD M6x10	2	
5	80241	GEAR IDLE, STARTER	1	
6	80239	GEAR, COMP, 5-SPEED	1	
7	83796	OIL SEAL, $\Phi 29 \times \Phi 17 \times 5$	1	
8	86420	PLATE, FIXING SPROCKET DRIVE	1	
9	80243	RETAINING RING $\Phi 16$	1	
10	86419	SPROCKET, DRIVE 15T	1	
11	80242	WASHER, $\Phi 23 \times \Phi 16.1 \times 0.5$	2	

## 08. GEARBOX MECHANISM

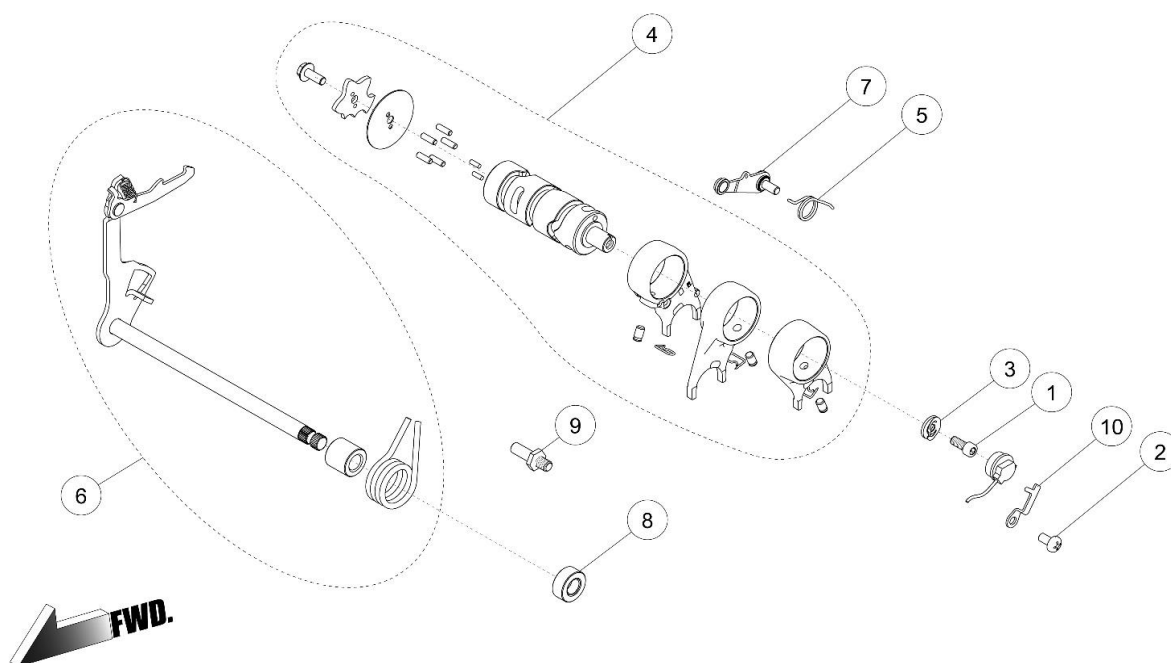

Ref No.	Part No.	DESCRIPTION	QTY	REMARK
1	86449	BOLT, HEXAGON SOCKET M6	1	
2	85877	SCREW, M6x12	1	
3	83833	CONTACT, GEAR INDICATION	1	
4	89744	DRUM, SHIFT 1-N-2-3-4-5 COMP	1	
5	88424	SPRING, LOCATING PLATE	1	
6	88886	LEVER, GEAR SHIFT COMP	1	
7	86424	LOCATING PLATE UNIT	1	
8	83837	OIL SEAL, $\phi 11.6 \times \phi 24 \times 10$	1	
9	86480	PIN, LOCATING SHIFT LEVER	1	
10	85876	PLATE, LOCATING SWITCH NEUTRAL	1	



# 09. OIL PUMP

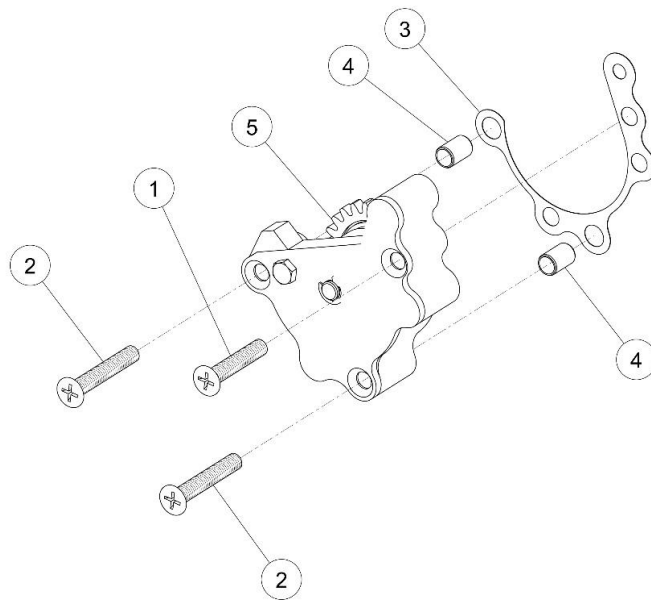

Ref No.	Part No.	DESCRIPTION	QTY	REMARK
1	84678	BOLT, CROSS RECESSED COUNTERSUNK M6x30	1	
2	84677	BOLT, CROSS RECESSED COUNTERSUNK M6x35	2	
3	84676	GASKET, PUMP OIL	1	
4	83747	PIN, DOWEL $\Phi 8 \times \Phi 6.3 \times 12$	2	
5	86382	PUMP, OIL ASSY	1	

# 10. KICK STARTER

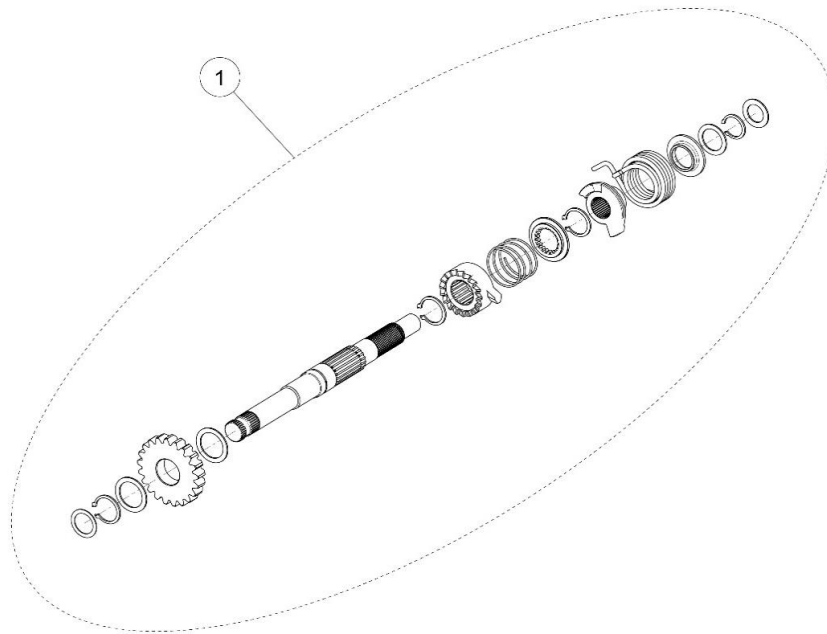

Ref No.	Part No.	DESCRIPTION	QTY	REMARK
1	88883	KICK STARTING SHAFT ASSY	1	

# 11. GENERATOR

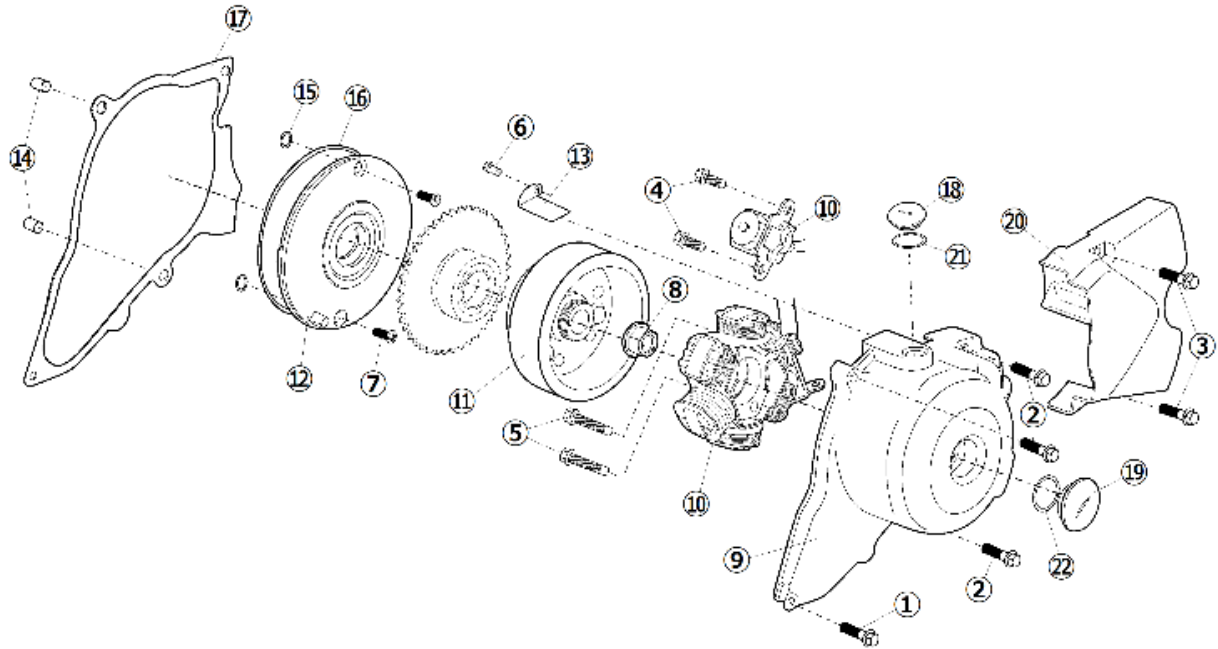

Ref No.	Part No.	DESCRIPTION	QTY	REMARK
1	86470	BOLT, M6X25	1	
2	88877	BOLT, M6X35	3	
3	88881	BOLT, M6X28	2	
4	88890	BOLT, M5X12	2	
5	86470	BOLT, M6X25	2	
6	88873	BOLT, M6X16	1	
7	86461	BOLT, CROSS RECESSED COUNTERSUNK M6x15	2	
8	88889	NUT	1	
9	88878	MAGNET COVER(SHOT BLAST)	1	
10	88425	STATOR ASSY MAGNETO	1	
11	88887	ROTOR ASSY, MAGNET	1	
12	88872	DISK INSULATOR	1	
13	88874	FIXING PLATE	1	
14	83747	PIN, DOWEL $\Phi 8 \times \Phi 6.3 \times 12$	2	
15	86479	O-RING, $\Phi 6.5 \times \Phi 1.8$	2	
16	84222	O-RING, $\Phi 110 \times \Phi 2.0$	1	
17	88410	GASKET L.CRANKCASE COVER	1	
18	88875	CAP, SMALL HOLE	1	
19	88880	CAP, BIG HOLE	1	
20	88882	SPROCKET COVER	1	
21	88876	O-RING, 13.2X2.65	1	
22	88879	O-RING, 27.4X2.65	1	

## 12. ELECTRIC STARTER

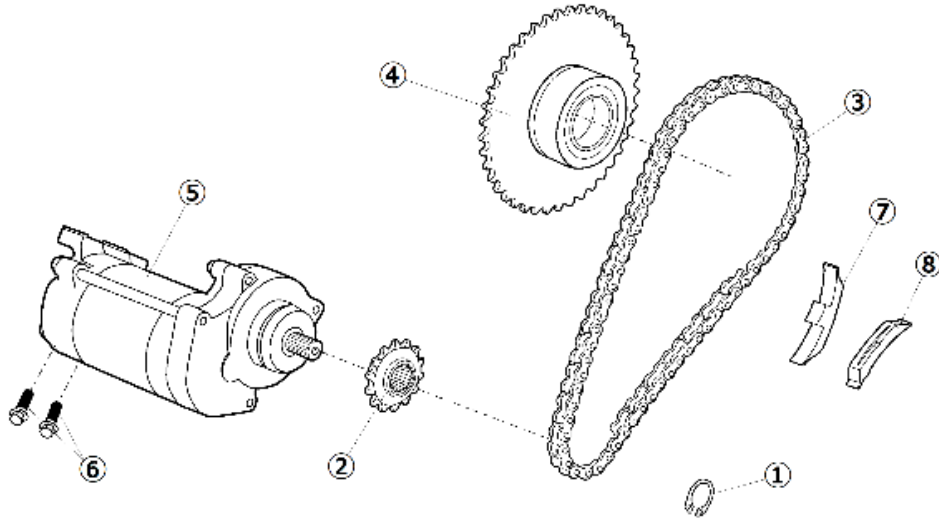

Ref No.	Part No.	DESCRIPTION	QTY	REMARK
1	88891	RETAINING RING, 11	1	
2	88892	SPROCKET	1	
3	88427	STARTING MOTOR DRIVE CHAIN	1	66L
4	88893	PLATE GEAR ASSY	1	
5	88426	STARTING MOTOR ASSY	1	
6	88894	BOLT, M6X22	2	
7	88420	GUIDE, PLATE	1	
8	88419	PLATE, CHAIN	1	

PL-ANIMA190FE

# 13. ELECTRICAL PARTS

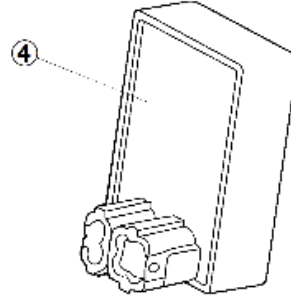
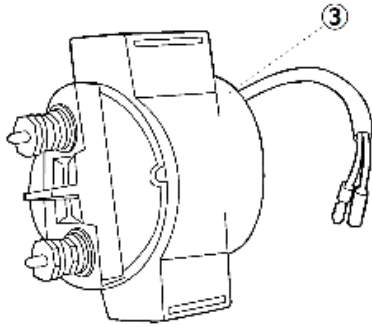
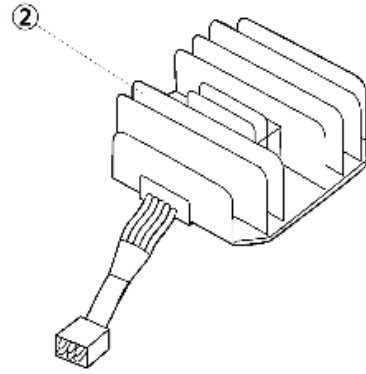
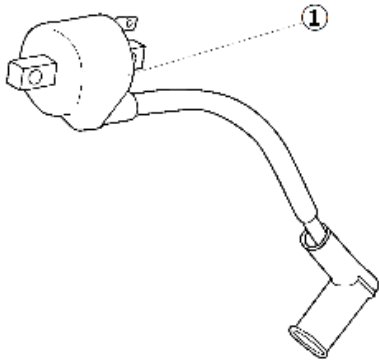

Ref No.	Part No.	DESCRIPTION	QTY	REMARK
1	86426	COIL, IGNITION	1	
2	88896	RECTIFIER	1	
3	88897	RELAY	1	
4	88895	CDI	1	
OP	89416	WIRE HERNESS (OPTION)	(1)	