

# 01 HEAD / CYLINDER

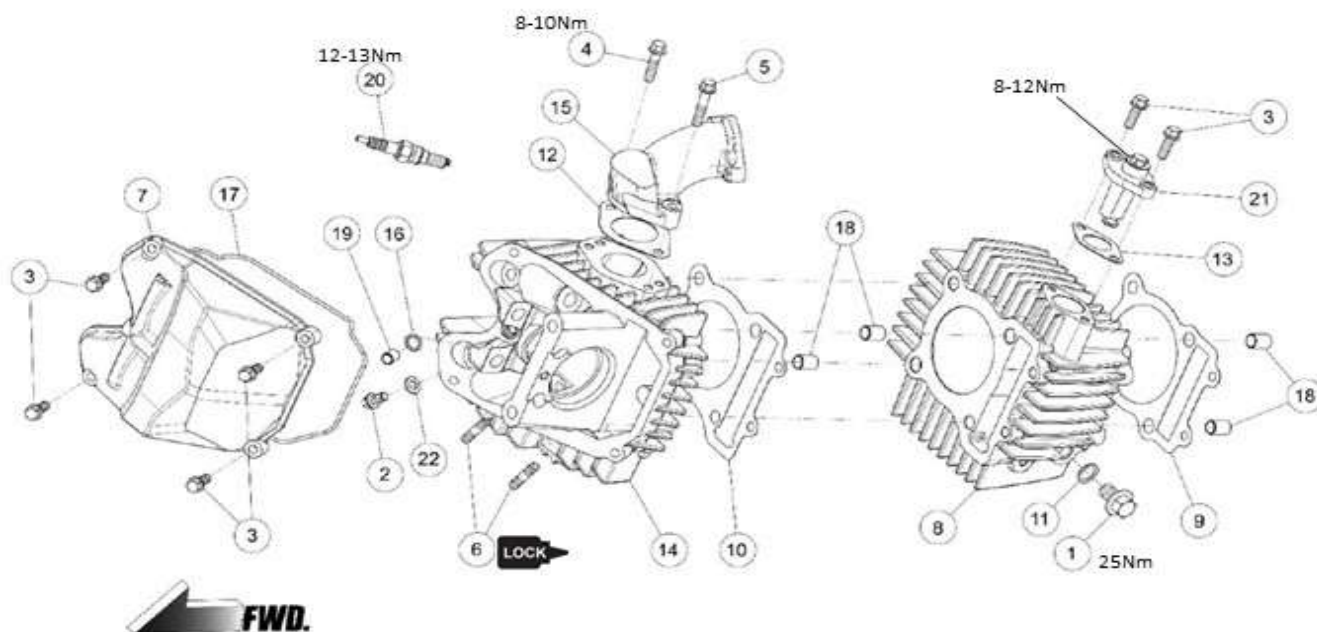

Unless otherwise specified threads  
M6=10Nm  
M8=20Nm

Ref#	PartNo.	DESCRIPTION	QTY	190FE(-3641)	190FE(3642-)
1	86448	BOLT, HEXAGON FLANGE M10x16	1	●	●
2	85877	BOLT, HEXAGON FLANGE M6x12	1	●	●
3	86468	BOLT, HEXAGON FLANGE M6x18	6	●	●
4	86466	BOLT, HEXAGON FLANGE M6x25	1	●	●
5	86471	BOLT, HEXAGON FLANGE M6x30	1	●	●
6	83703	BOLT, STUD M6x32	2	●	●
7	88250	COVER, CYLINDER HEAD, BLACK	1	●	●
8	89237	CYLINDER, 66MM, with starter model	1	●	●
9	89458	GASKET, BASE CYLINDER	1	●	●
10	86440	GASKET, HEAD CYLINDER, ANIMA4V	1	●	●
11	86476	GASKET, M10	1	●	●
12	86405	GASKET, MANIFOLD	1	●	●
13	86439	GASKET, TANSIONER CAM CHAIN	1	●	●
14	86368	HEAD, CYLINDER	1	●	●
15	86404	MANIFOLD, INTAKE	1	●	●
16	86479	O-RING	1	●	●
17	86434	O-RING, COVER HEAD	1	●	●
18	83720	PIN, DOWEL $\Phi 10 \times \Phi 8.4 \times 14$	4	●	●
19	83747	PIN, DOWEL $\Phi 8 \times \Phi 6.3 \times 12$	1	●	●
20	86429	SPARK PLUG ER9EH-6N	1	●	●
20	87008	SPARK PLUG ER9EH ✕OPTION	1	OPTION	OPTION
21	86396	TENSIONER, CAM CHAIN COMP	1	●	●
22	86456	WASHER, $\Phi 6.3 \times \Phi 12 \times 1.5$	1	●	●

# O2 VALVE MECHANISM

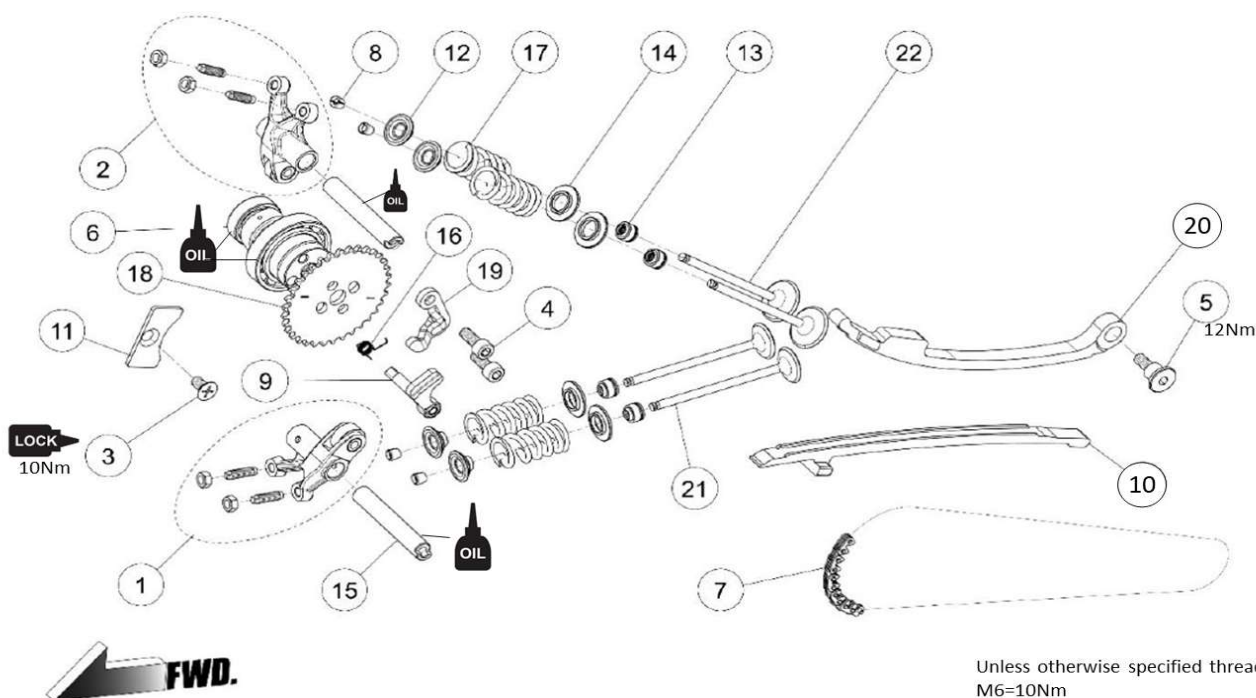

Unless otherwise specified threads  
 M6=10Nm  
 M8=20Nm

Ref#	PartNo.	DESCRIPTION	QTY	190FE(-3641)	190FE(3642-)
1	86481	ARM, ROCKER ROLLER EXHAUST COMP	1	●	●
2	86393	ARM, ROCKER ROLLER INTAKE COMP	1	●	●
3	86460	BOLT, COUNTERSINK M6x15	1	●	●
4	86883	SCREW M6X16	2	●	●
5	86447	BOLT, TENSIONER	1	●	●
6	87347	CAMSHAFT COMP, ECO-CAM (00)	1	●	●
6	86878	CAMSHAFT COMP, 190CC RACING 240°	1	OPTION	OPTION
7	86391	CHAIN, CAMSHAFT DRIVE 94L	1	●	●
8	86402	COTTER, VALVE	8	●	●
9	89681	SHAFT W/WEIGHT,DECOMP. VER3	1	●	●
10	86395	GUIDE , CHAIN CAMSHAFT	1	●	●
11	86389	PLATE, STOPPER CAM	1	●	●
12	86400	RETAINER, SPRING VALVE	4	●	●
13	86403	SEAL, VALVE STEM Φ4.5	4	●	●
14	86401	SEAT, SPRING VALVE	4	●	●
15	86392	SHAFT, ROCKER	2	●	●
16	87621	SPRING,RETURN DECOMP. VER2	1	●	●
17	86624	SPRING,VALVE (GREEN MARKED)	4	●	●
18	86879	SPROCKET, CAMSHAFT DRIVEN	1	●	●
19	87620	PLATE,STOPPER DECOMP. VER2	1	●	●
20	86394	TENSIONER, CAM CHAIN	1	●	●
21	86623	VALVE, EXHAUST Φ21	2	●	●
22	86397	VALVE, INTAKE Φ24.5	2	●	●

# 03 PISTON / CRANKSHAFT

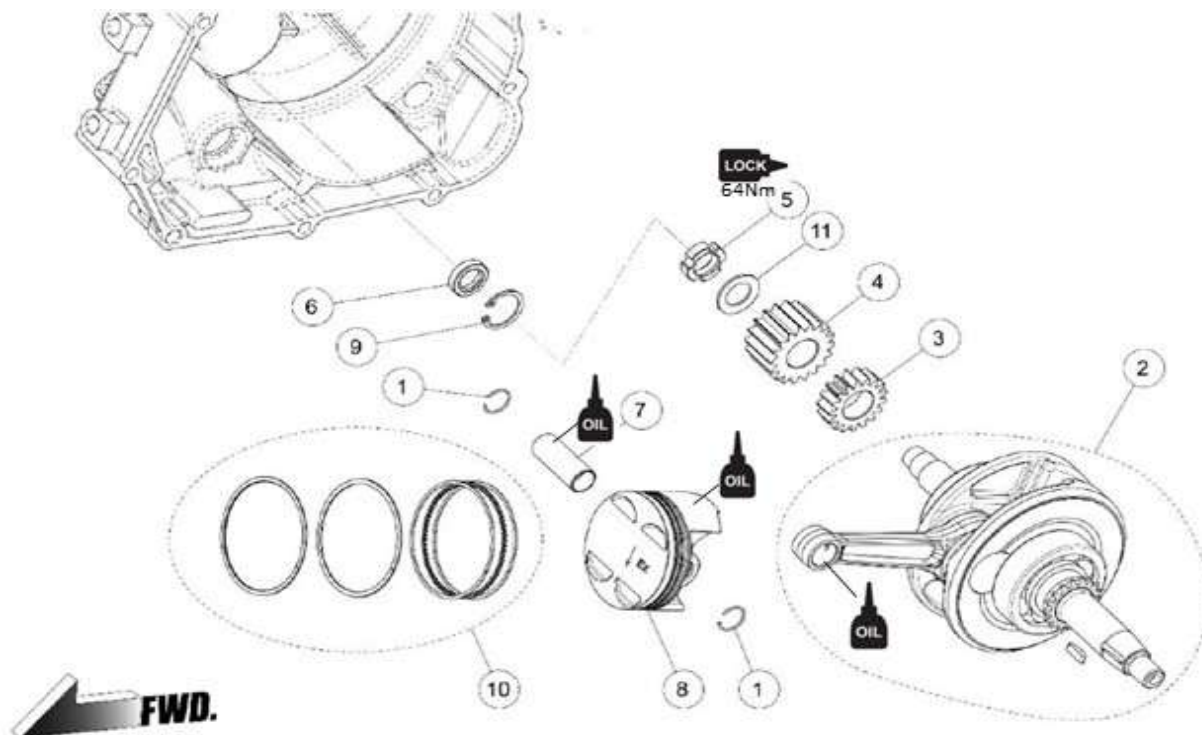

Ref#	PartNo.	DESCRIPTION	QTY	190FE(-3641)	190FE(3642-)
1	86453	CLIP, PIN PISTON	2	●	●
2	88421	CRANK SHAFT ASSY, ANIMA FE	1	●	●
3	86383	GEAR, OIL PUMP DRIVE	1	●	●
4	86415	GEAR, PRIMARY DRIVE	1	●	●
5	83768	NUT, SMALL M14	1	●	●
6	86443	OIL SEAL, Φ12xΦ20x5t	1	●	●
7	86379	PIN, PISTON L=36.5 FOR 62MM	1	●	●
8	86621	PISTON DT190F, 62MM	1	●	●
9	86462	RETAINING RING, RTWN22	1	●	●
10	86380	RING SET, FOR PISTON 62MM	1	●	●
11	86411	WASHER, SPRING	1	●	●

# 04 CRANKCASE

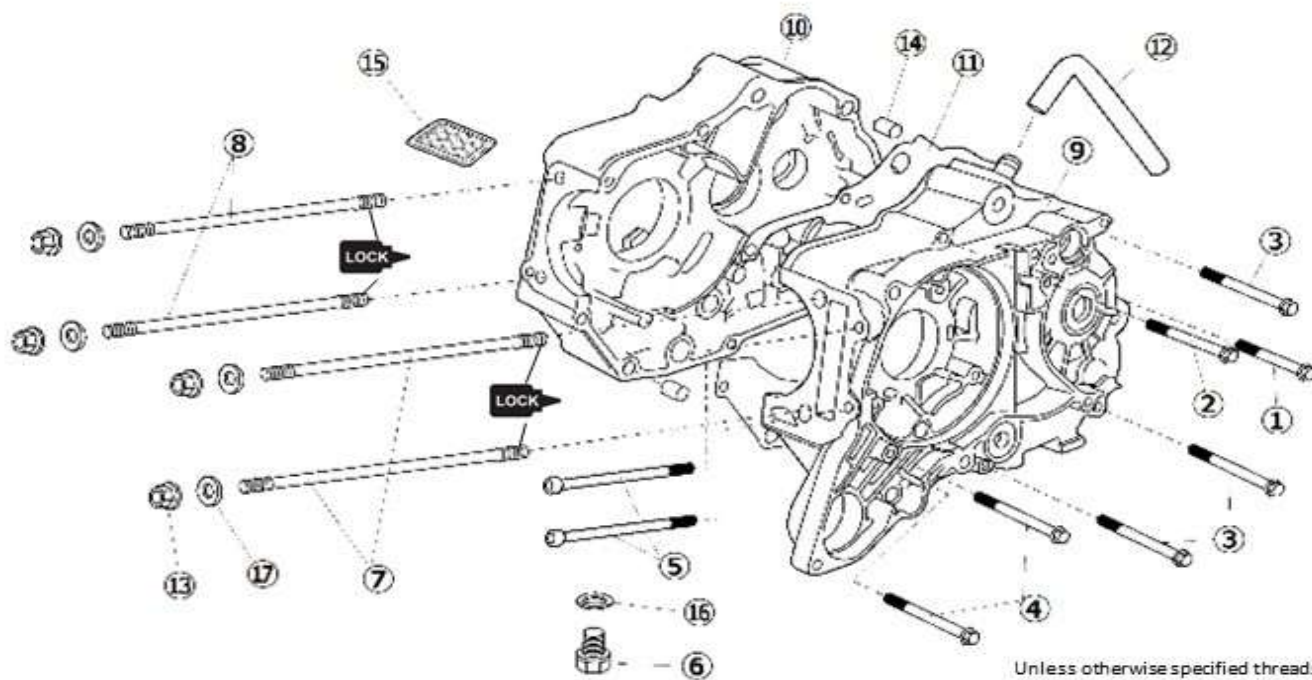

Unless otherwise specified threads  
 M6=10Nm  
 M8=20Nm

Ref#	PartNo.	DESCRIPTION	QTY	190FE(-3641)	190FE(3642-)
1	86474	BOLT, HEXAGON FLANGE M6x55	1	•	•
2	83761	BOLT, HEXAGON FLANGE M6x65	1	•	•
3	86360	BOLT, HEXAGON FLANGE M6x70	5	•	•
4	88864	BOLT, HEXAGON FLANGE M6x80	2	•	•
5	86459	BOLT, HEXAGON SOCKET M6x108	2	•	•
6	81008	BOLT, OIL DRAIN M12x15 WITH MAGNET	1	•	•
6	83755	BOLT, OIL DRAIN M12x15	1	•	•
7	86444	BOLT, STUD A	2	•	•
8	86445	BOLT, STUD B	2	•	•
9	88847	CRANKCASE,LH ANIMA FE	1	•	•
10	88848	CRANKCASE,RH ANIMA FE	1	•	•
11	86438	GASKET, CRANKCASE	1	•	•
12	86371	HOSE, BREATHER	1	•	•
13	86451	NUT FLANGE, M8	4	•	•
14	83720	PIN, DOWEL $\Phi 10 \times \Phi 8.4 \times 14$	2	•	•
15	83751	OIL FILTER SCREEN	1	•	•
16	83754	WASHER, OIL DRAIN M12	1	•	•
17	86457	WASHER, GASKET M8	4	•	•
18	88870	BOLT, M6X12	1	•	•
19	88871	PLATE, START CLUTCH	1	•	•

# 05 CLUTCH

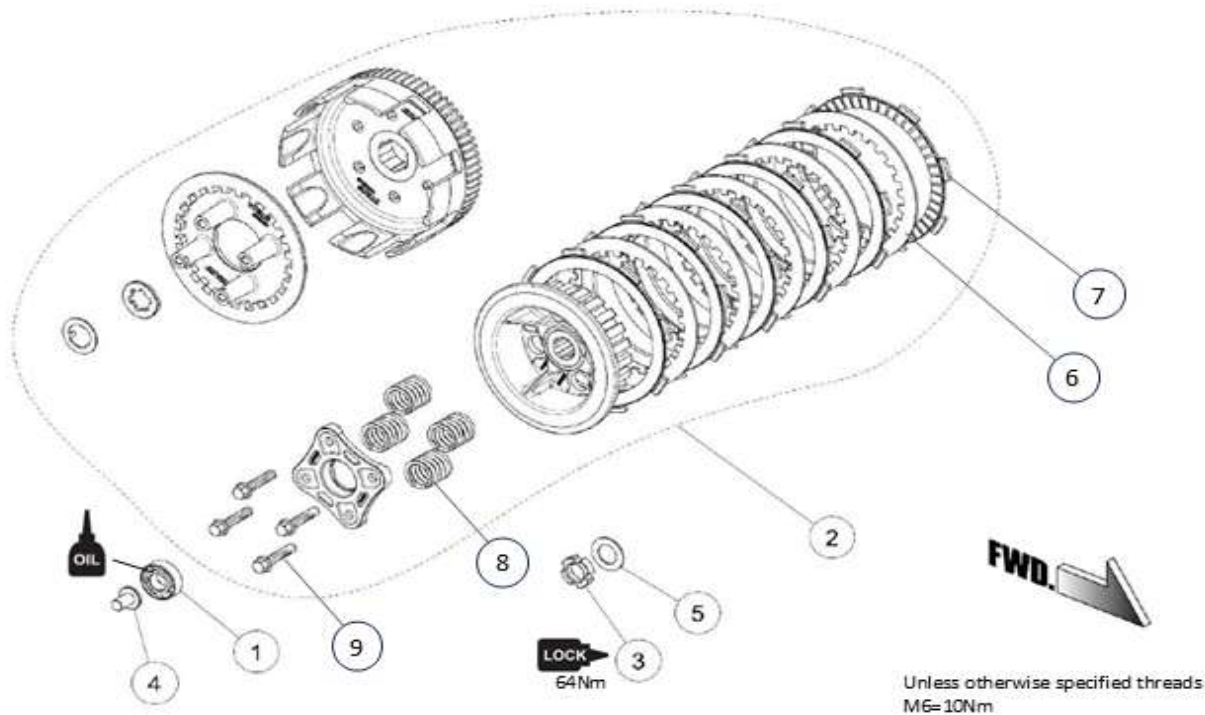

Ref#	PartNo.	DESCRIPTION	QTY	190FE(-3641)	190FE(3642-)
1	83786	BEARING, #6000	1	●	●
2	87619	CLUTCH COMP, W/FORGED GEAR	1	●	●
3	83768	NUT, SMALL M14	1	●	●
4	83787	PIN, LIFTER CLUTCH	1	●	●
5	86410	WASHER, SPRING $\Phi 24 \times \Phi 14.2 \times 1.2$	1	●	●
6	81356	CLUTCH FRICTION DISK ,1PCS	6	●	●
7	81357	CLUTCH STEEL PLATE ,1PCS	5	●	●
8	81586	SPRING , CLUTCH 1PCS	4	●	●
9	81478	BOLT, PLESSURE PLATE 1PCS	4	●	●

# 06 COVER CLUTCH

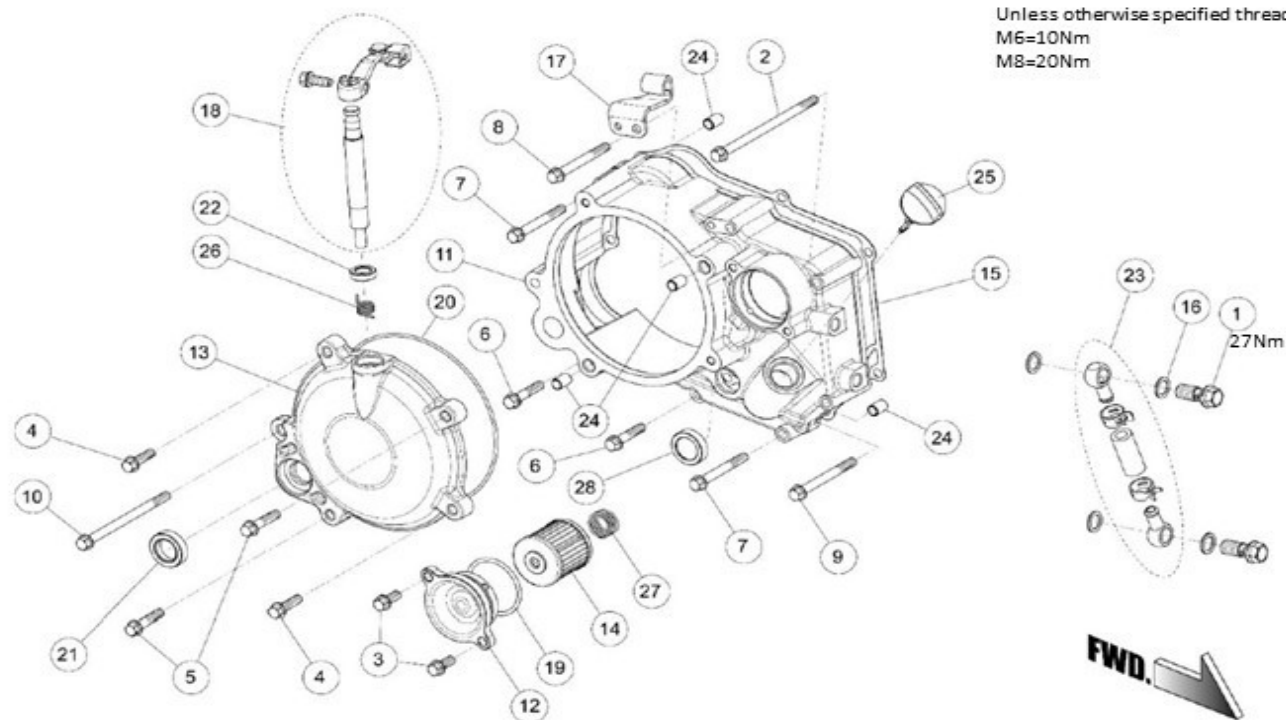

Unless otherwise specified threads  
 M6=10Nm  
 M8=20Nm

Ref#	PartNo.	DESCRIPTION	QTY	190FE(-3641)	190FE(3642-)
1	86446	BOLT, BANJO M10x22.5	2	●	●
2	88862	BOLT, HEXAGON FLANGE M6x115	1	●	●
3	88873	BOLT, HEXAGON FLANGE M6x16	2	●	●
4	86469	BOLT, HEXAGON FLANGE M6x22	2	●	●
5	86485	BOLT, HEXAGON FLANGE M6x28	2	●	●
6	86471	BOLT, HEXAGON FLANGE M6x30	2	●	●
7	86473	BOLT, HEXAGON FLANGE M6x50	2	●	●
8	86474	BOLT, HEXAGON FLANGE M6x55	1	●	●
9	83759	BOLT, HEXAGON FLANGE M6x60	1	●	●
10	86361	BOLT, HEXAGON FLANGE M6x90	1	●	●
11	88863	COVER, CLUTCH, 190FE	1	●	●
12	86374	COVER, OIL FILTER	1	●	●
13	86377	COVER, SMALL CLUTCH	1	●	●
14	86384	FILTER, OIL	1	●	●
15	86437	GASKET, COVER CLUTCH	1	●	●
16	86476	GASKET, M10	4	●	●
17	86412	HOLDER, CABLE CLUTCH	1	●	●
18	86414	LEVER, CLUTCH COMP	1	●	●
19	86432	O-RING, Φ38.6x2.6	1	●	●
20	86435	O-RING, COVER SMALL CLUTCH	1	●	●
21	86441	OIL SEAL, Φ16xΦ26x7	1	●	●
22	86442	OIL SEAL, Φ17xΦ10x5	1	●	●
23	86406	OIL THROUGH COMP	2	●	●
24	83747	PIN, DOWEL Φ8xΦ6.3x12	4	●	●
25	86386	RULER	1	●	●
26	86413	SPRING, LEVER CLUTCH	1	●	●
27	86375	SPRING, OIL FILTER	1	●	●
28	86475	WINDOW, OIL LEVEL	1	●	●



# 07 GEARBOX

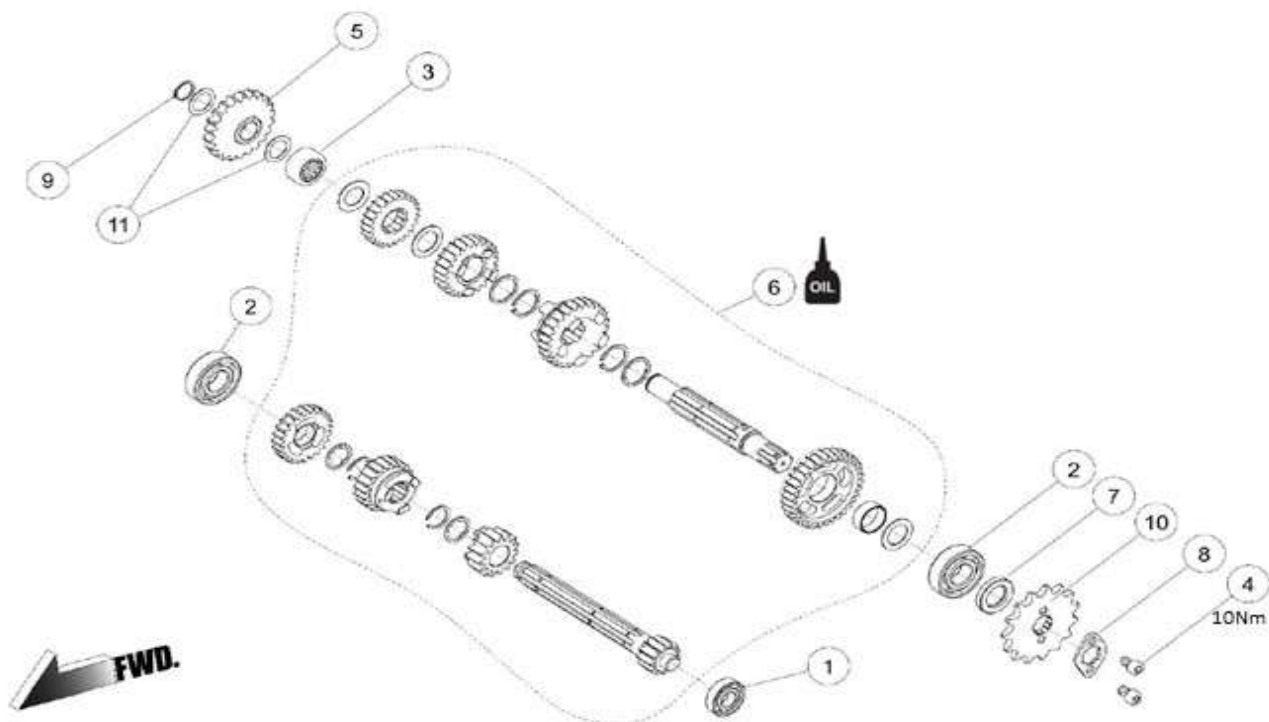

Ref#	PartNo.	DESCRIPTION	QTY	190FE(-3641)	190FE(3642-)
1	83788	BEARING #6001	1	●	●
2	83795	BEARING #6203	2	●	●
3	80240	BEARING NK162712	1	●	●
4	86464	BOLT, HEXAGON SOCKET M6x10	2	●	●
5	80241	GEAR IDLE, STARTER, 5SPEED	1	●	●
6	80239	GEAR, COMP, 5SPEED, 1-N2345	1	●	●
7	83796	OIL SEAL, Φ29xΦ17x5	1	●	●
8	86420	PLATE, FIXING SPROCKET DRIVE	1	●	●
9	80243	RETAINING RING Φ16	1	●	●
10	81256	SPROCKET, DRIVE 428-16T	1	OPTION	OPTION
10	86419	SPROCKET, DRIVE 428-15T	1	●	●
11	80242	WASHER, Φ23xΦ16.1x0.5	2	●	●

# 08 GEARBOX MECHANISM

Unless otherwise specified threads  
 M6=10Nm  
 M8=20Nm

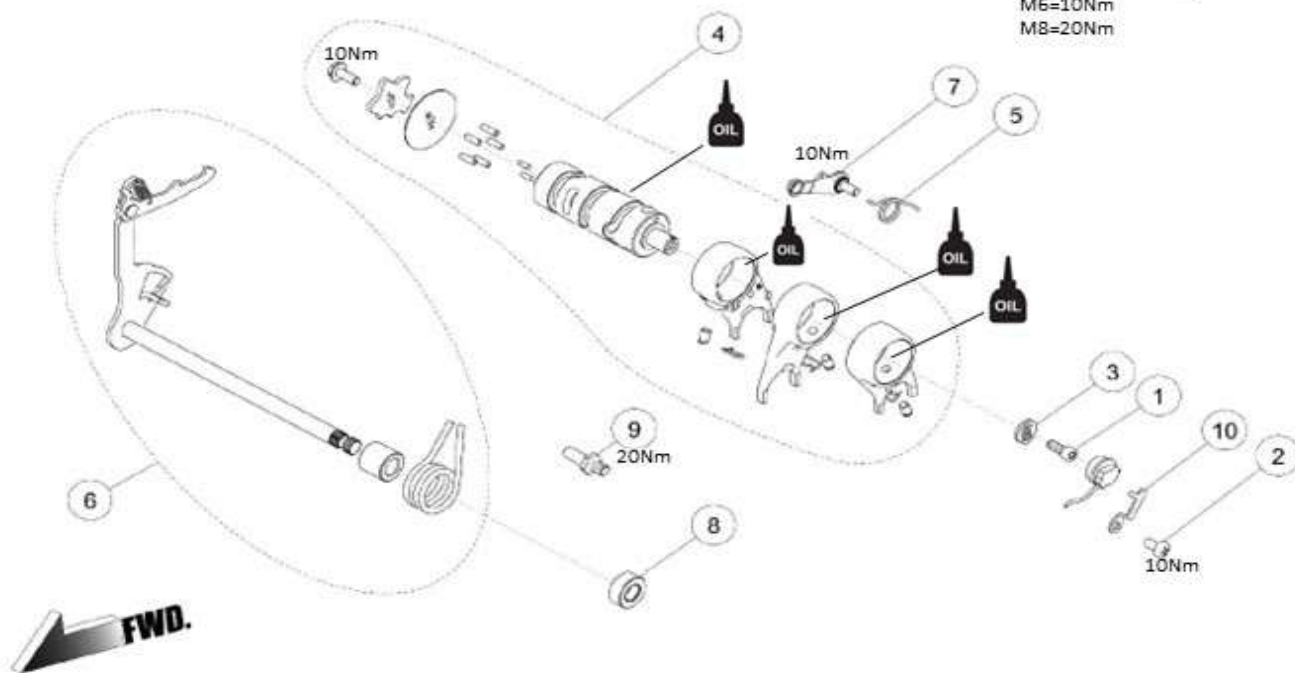

Ref#	PartNo.	DESCRIPTION	QTY	190FE(-3641)	190FE(3642-)
1	86449	BOLT, HEXAGON SOCKET M6	1	●	●
2	85877	BOLT, HEXAGON SOCKET M6x15	1	●	●
3	83833	CONTACT, GEAR INDICATION	1	●	●
4	89744	DRUM, SHIFT COMP, 5SPEED, 1-N2345	1	●	●
5	88424	SPRING, LOCATING PLATE, 5SPEED	1	●	●
6	88886	LEVER, GEAR SHIFT COMP, 5SPEED	1	●	●
7	86424	LOCATING PLATE UNIT	1	●	●
8	83837	OIL SEAL, Φ11.6xΦ24x10	1	●	●
9	86480	PIN, LOCATING SHIFT LEVER	1	●	●
10	85876	PLATE, LOCATING SWITCH NEUTRAL	1	●	●



# 09 OIL PUMP

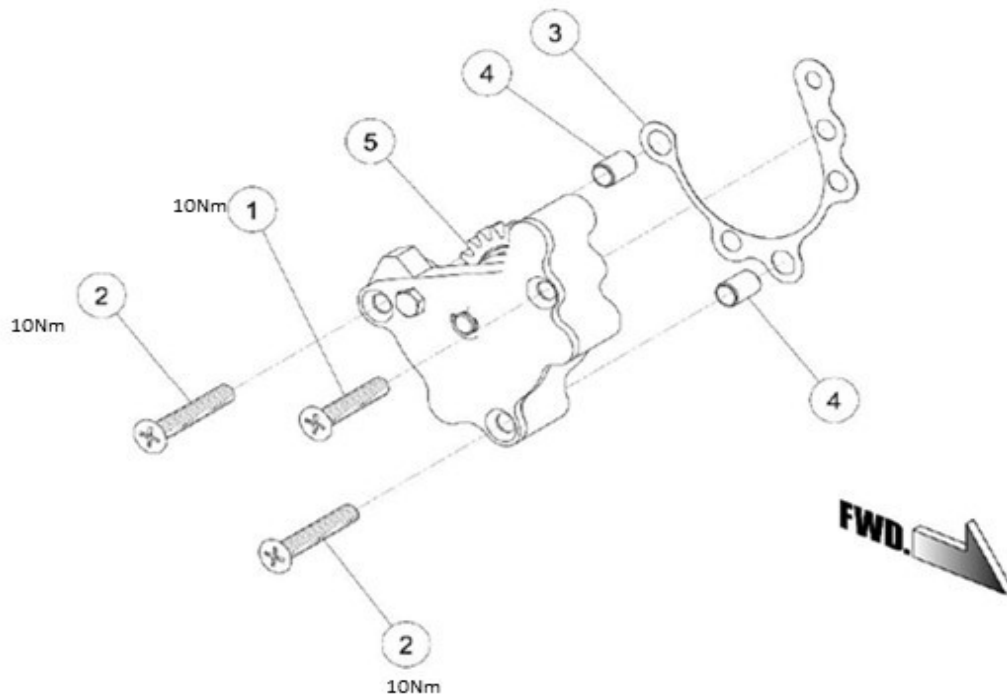

Ref#	PartNo.	DESCRIPTION	QTY	190FE(-3641)	190FE(3642-)
1	84678	BOLT, CROSS RECESSED COUNTERSUNK M6x35	1	•	•
2	84677	BOLT, CROSS RECESSED COUNTERSUNK M6x40	2	•	•
3	84676	GASKET, PUMP OIL	1	•	•
4	83747	PIN, DOWEL $\Phi 8 \times \Phi 6.3 \times 12$	2	•	•
5	86382	PUMP, OIL ASSY	1	•	•

# 10 KICK STARTER

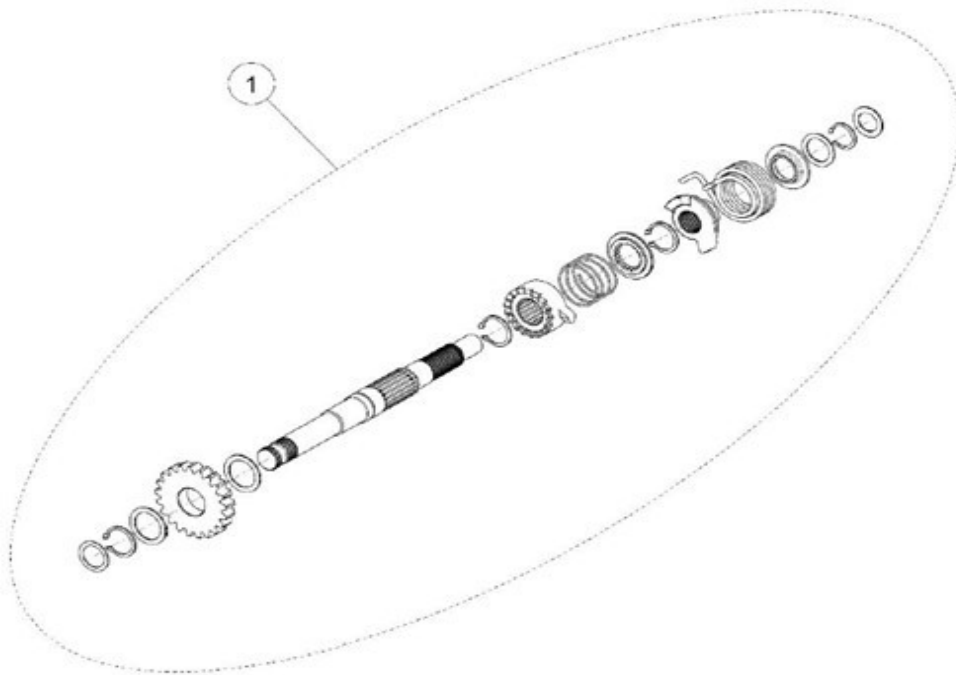

Ref#	PartNo.	DESCRIPTION	QTY	190FE(-3641)	190FE(3642-)
1	88883	KICK STARTING SHAFT ASSY, 5SPEED	1	•	•

# 11 GENERATOR

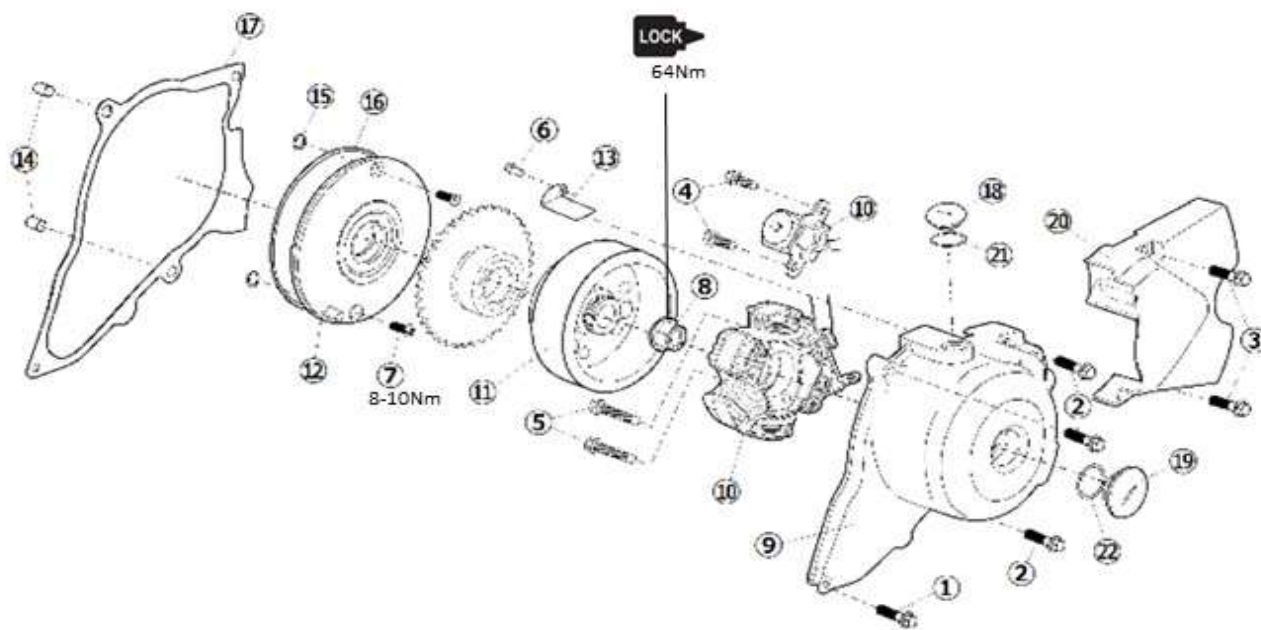

Unless otherwise specified threads  
M6=10Nm

Ref#	PartNo.	DESCRIPTION	QTY	190FE(-3641)	190FE(3642-)
1	86470	BOLT, M6X25	1	●	●
2	88877	BOLT, M6X35	3	●	●
3	88881	BOLT, M6X28	2	●	●
4	88890	BOLT, M5X12	2	●	●
5	86470	BOLT, M6X25	2	●	●
6	88873	BOLT, M6X16	1	●	●
7	86461	BOLT, CROSS RECESSED COUNTERSUNK M6x15	2	●	●
8	88889	NUT	1	●	●
9	88878	MAGNETO COVER(SHOT BLAST)	1	●	●
10	88425	STATOR ASSY, WITH LIGHT, ANIMA FE	1	●	●
11	81303	ROTOR ASSY, FOR W/E-STARTER MODEL, SELECTABLE CDI	1		●
11	88887	ROTOR ASSY, FOR W/E-STARTER MODEL	1	●	
12	88872	DISK INSULATOR	1	●	●
13	88874	FIXING PLATE	1	●	●
14	83747	PIN, DOWEL $\Phi 8 \times \Phi 6.3 \times 12$	2	●	●
15	86479	O-RING, $\Phi 6.5 \times \Phi 1.8$	2	●	●
16	84222	O-RING, $\Phi 110 \times \Phi 2.0$	1	●	●
17	88410	GASKET L.CRANKCASE COVER	1	●	●
18	88875	CAP, SMALL HOLE	1	●	●
19	88880	CAP, BIG HOLE	1	●	●
20	88882	SPROCKET COVER	1	●	●
21	88876	O-RING, 13.2X2.65	1	●	●
22	88879	O-RING, 27.4X2.65	1	●	●



**ANIMA190FE : Please check your serial number.**

190FE( 3642000000~) Please see the row 190FE(3642-)

190FE(~3641000000 ) Please see the row 190FE(-3641)

**Parts List : ANIMA 4V 190FE (5Speed with E-start)**  
**12 ELECTRICAL STARTER,ELECTRICAL**

V9\_DAYTONA JAPAN

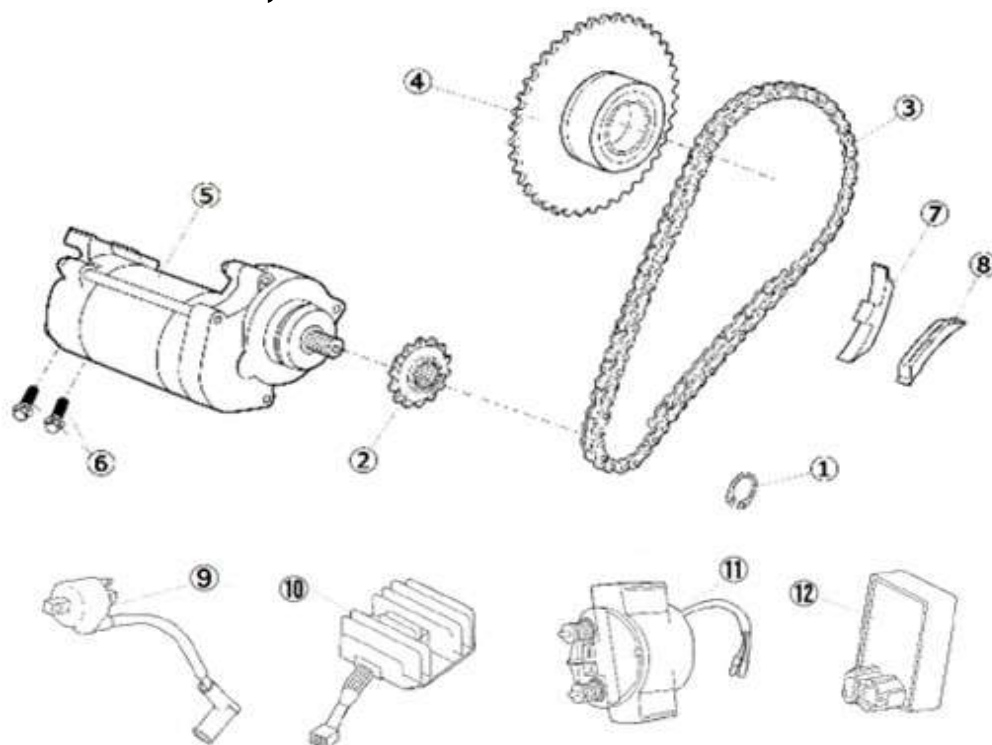

Ref#	PartNo.	DESCRIPTION	QTY	190FE(-3641)	190FE(3642-)
1	88891	RETAINING RING, 11	1	●	●
2	88892	SPROCKET,STARTER MOTOR	1	●	●
3	88427	STARTING MOTOR DRIVE CHAIN	1	●	●
4	88893	PLATE GEAR ASSY	1	●	●
5	88426	STARTING MOTOR ASSY	1	●	●
6	88894	BOLT, M6X22	2	●	●
7	88420	GUIDE, PLATE	1	●	●
8	88419	PLATE, CHAIN	1	●	●
9	86426	COIL, IGNITION	1	●	●
10	88896	RECTIFIER	1	●	●
11	88897	RELAY	1	●	●
12	87349	CDI, SELEVTABLE REV & TIMING	1		●
12	88895	CDI	1	●	



**ANIMA190FE : Please check your serial number.**

**190FE( 3642000000~) Please see the row 190FE(3642-)**

**190FE(~3641000000 ) Please see the row 190FE(-3641)**