

#81943, 81944, 81945

ULTRALIGHT ALUMINUM CLUTCH PLATE KIT

 Lockite Application

 Oil Application

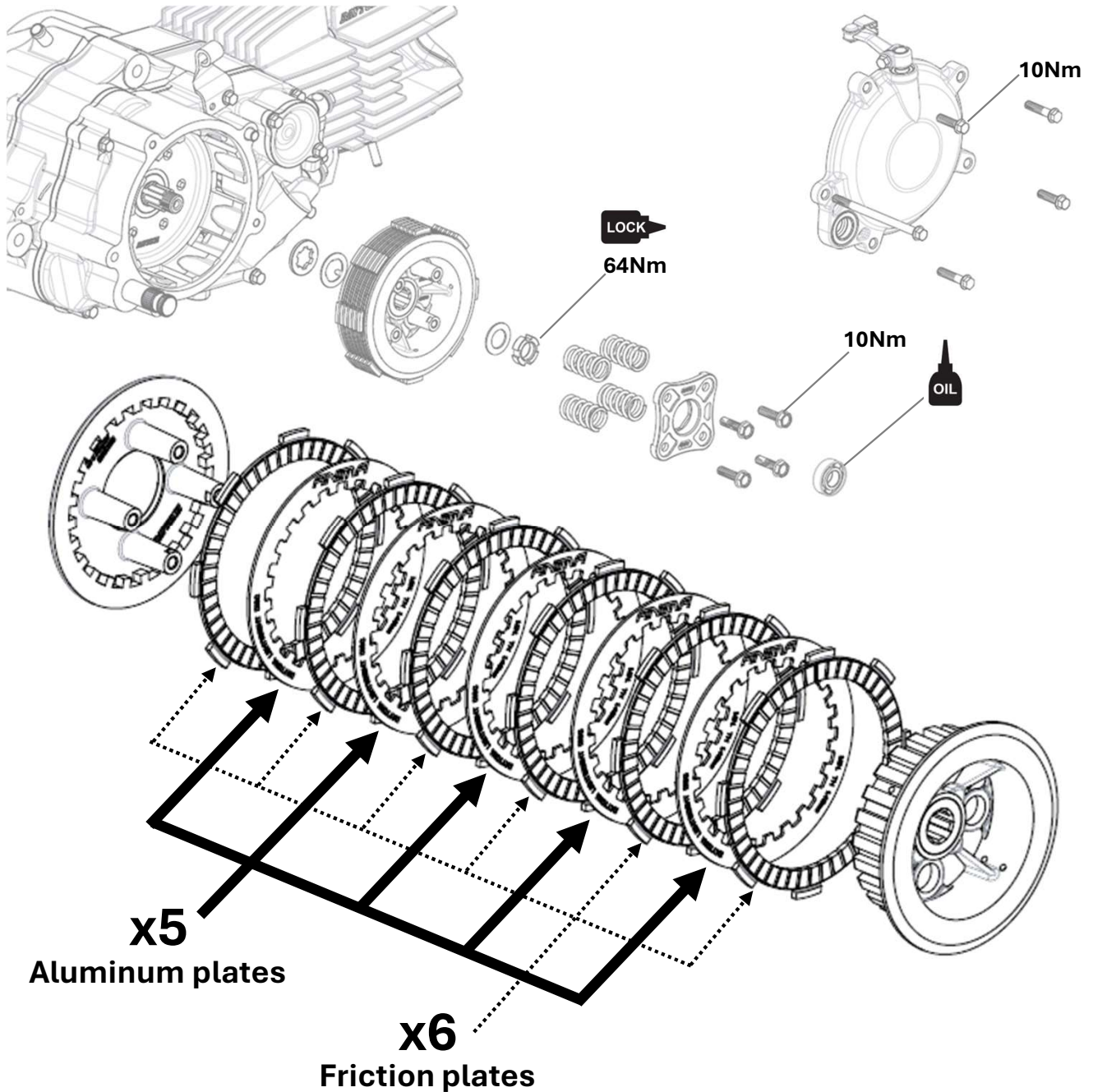

Usage Limits

Aluminum Plate : 1.45 mm (0.057 in)

Friction Plate : 2.7 mm (0.106 in)

Recommended Tools

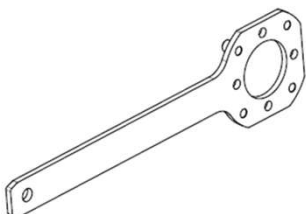

#80910
PRESSURE PLATE TOOL



#80221
LOCK NUT TOOL



Homepage

#81943, 81944, 81945

ULTRALIGHT ALUMINUM CLUTCH PLATE KIT

 Application Loctite

 Application d'huile

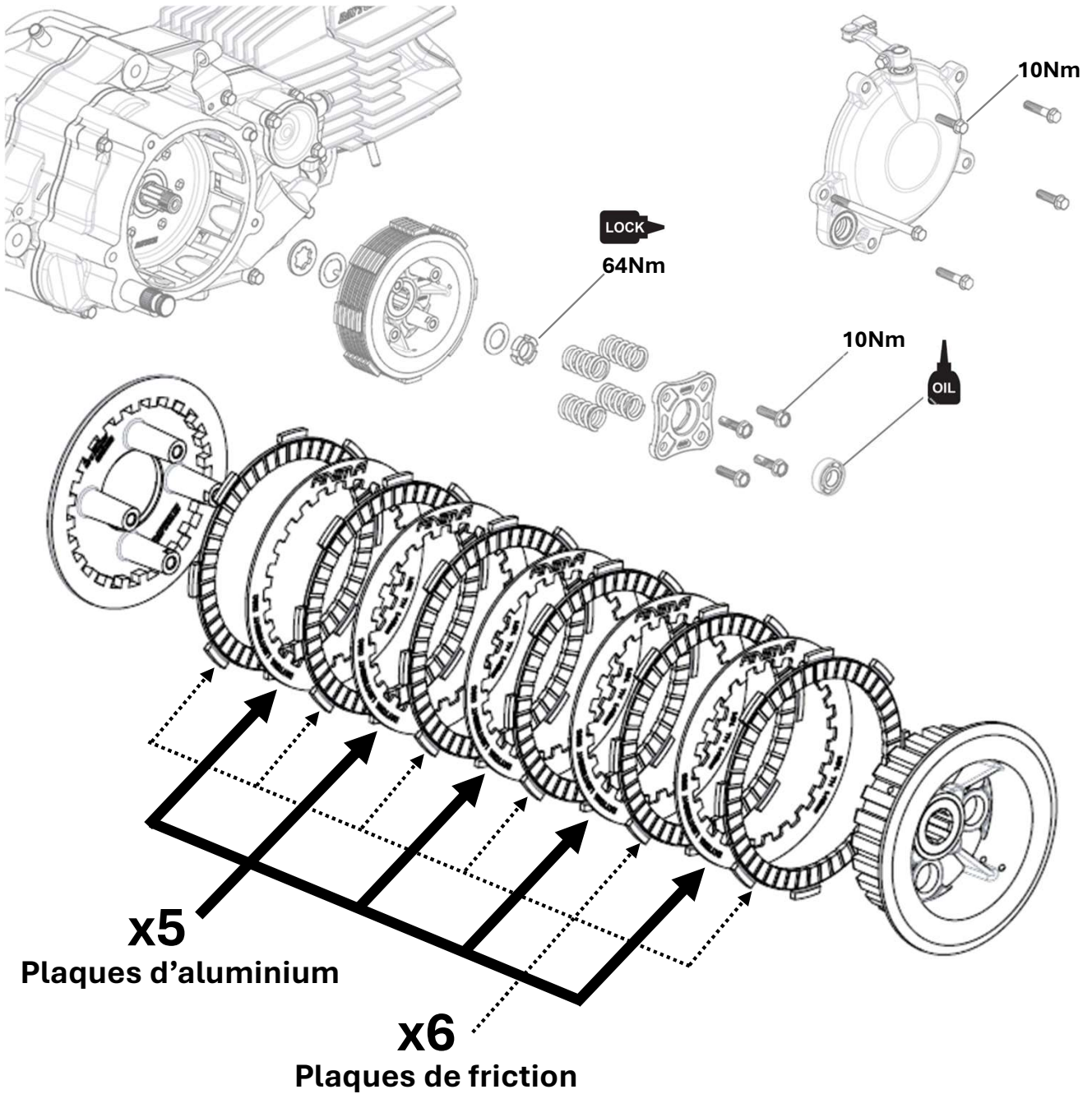

Limites d'utilisation

Plaques d'aluminium : 1.45 mm (0.057 in)

Plaques de friction : 2.7 mm (0.106 in)

Outils recommandés

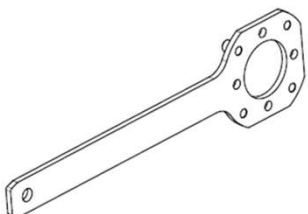

#80910
PRESSURE PLATE TOOL



#80221
LOCK NUT TOOL



Homepage